

Capacity 500 kg



## Hydraulic Wheel Dolly

The Stertil-Koni WD-5P is a fully hydraulic high lift wheel dolly, simplifying the strenuous task of wheel and tyre maintenance. Manufactured to high ergonomic standards with robust steel framing and covers for foot protection. An ultimate ergonomic design.

- Suitable for all wheels and tyres: single and double 800-1200 mm
- Air-driven hydraulic pump with adjustable speed
- Precision alignment with hydraulic tilting forks and separate rollers for first and second wheel
- Open chassis for extra working space and accessibility
- Retaining bracket for secure removal and reinstallation of wheels and tyres
- Swivel castors for easy manoeuvrability and positioning
- Fully adjustable air gun lifting aid holder



Safety



Ergonomic



Efficiency

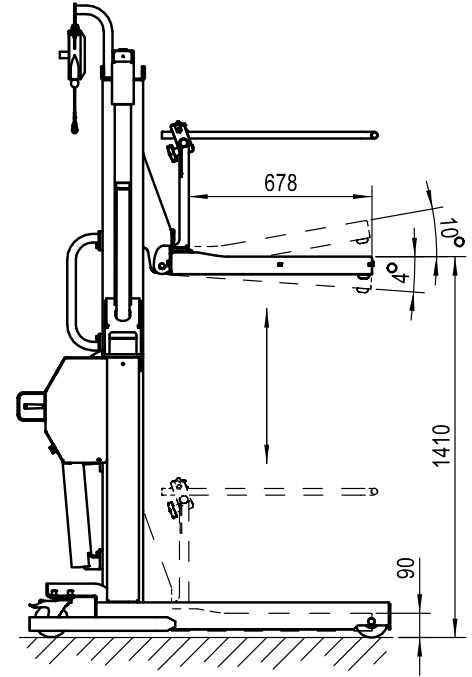
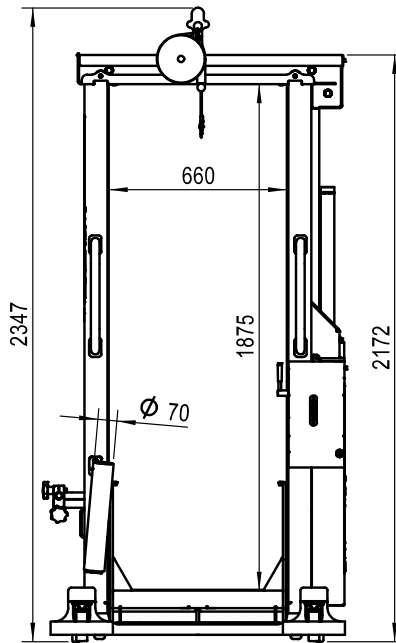
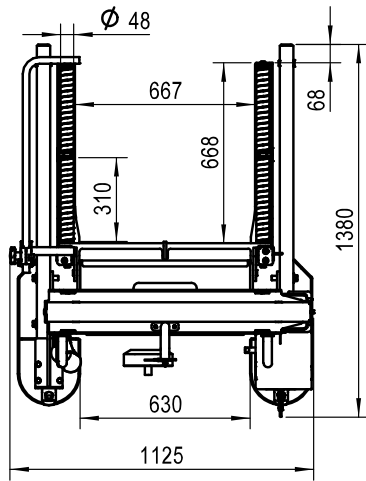

## Specifications WD-5P / High Lift Wheel Dolly

Capacity:	500 kg
Height:	2172 mm
Length:	1380 mm
Width:	1125 mm
Double Roller Length:	668 mm
Fork Length:	678 mm
Wheel Sizes	800 - 1200 mm
Lifting Height:	1410 mm
Lifting Speed:	45 mm/sec
Tilt Angles:	10° up 4° down
Pneumatic Operation Pressure:	5 – 10 Bar
Air Gun Balancer	9 – 14 kg
Weight:	260 kg

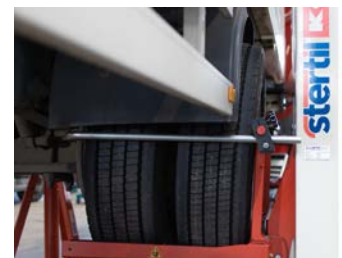

95003122 High Lift Wheel Dolly WD-5P-English UK. Stertil is a registered trademark of Stertil® B.V. We reserve the right to make changes in specifications without notice and without making changes retroactive.